

(12) **United States Patent**
Reed et al.

(10) **Patent No.:** **US 9,042,991 B2**
 (45) **Date of Patent:** **May 26, 2015**

(54) **IMPLANTABLE HEAD MOUNTED
 NEUROSTIMULATION SYSTEM FOR HEAD
 PAIN**

(71) Applicant: **Syntrilla Medical LLC, Dallas, TX (US)**

(72) Inventors: **Kenneth Lyle Reed, Dallas, TX (US);
 Robert Raymond Budget, Dallas, TX
 (US)**

(73) Assignee: **Syntrilla Medical LLC, Dallas, TX (US)**

(*) Notice: Subject to any disclaimer, the term of this
 patent is extended or adjusted under 35
 U.S.C. 120(b) by 0 day(s).

(21) Appl. No.: 14/460,139

(22) Filed: Aug. 14, 2014

(65) **Prior Publication Data**

US 2015/012400 A1 Apr. 23, 2015

Related U.S. Application Data

(60) Provisional application No. 61/864,795, filed on Oct.
 23, 2013.

(51) **Int. Cl.**
A61N 1/36 (2006.01)
A61N 1/05 (2006.01)

(52) **U.S. Cl.**
 CPC **A61N 1/36075** (2013.01); **A61N 1/0536**
 (2013.01); **A61N 1/0557** (2013.01);

(53) **Field of Classification Search**
 CPC **A61N 1/0551**; **A61N 1/15075**; **A61N**
1/36075; **A61N 1/0553**
 USPC **607/40**, **29**, **50**, **116**, **138**
 See application file for complete search history

(56) **References Cited**

U.S. PATENT DOCUMENTS

5,217,089 A	61,993	Tang, et al.
5,616,449 A	17,000	Piacht et al.
5,529,774 B1	32,000	Greene
5,397,094 B1	29,000	Phillis et al.
5,666,521 B2	52,000	Prager et al.
5,678,675 B1	67,000	Phillis et al.
5,930,369 B2	77,000	Vandeweyer et al.
7,127,298 B1	102,000	He et al.

(Continued)

OTHER PUBLICATIONS

Weizer RL and Reed KL. Pericranial nociceptation for control of
 intractable acute pain. *Neurol. Neurosurg. Neurorehabil.* (Journal of the
 International Neuromodulation Society, 1999, 2: 217-21)

(Continued)

Primary Examiner: Catherine Mvirisen

(74) *Attorney, Agent, or Firm:* — **Horizon & Anon, LLP**

(57) **ABSTRACT**

An implantable head-mounted primary pericranial neuro-
 stimulation system is provided for implantation in the head
 for the purpose of treating chronic head pain, including
 migraine. The system may include an implantable pulse gen-
 erator (IPG) from which multiple stimulating leads may
 extend sufficient to allow for adequate stimulation over mul-
 tiple regions of the head, preferably including the frontal,
 parietal and occipital regions. A cord may include an osseous
 body along which may be disposed a plurality of surface
 metal electrodes, which may be sub-divided into a plurality of
 electrode arrays. A plurality of internal metal wires may form a
 portion of its length and connect the IPG's internal circuit to
 the surface metal electrodes. The system may include a recharge-
 able battery, an external and/or implantable specific internal
 circuit. The IPG may be capable of functional connection
 with an external radio-frequency unit for purposes that may
 include recharging, diagnosis, configuration, and programming.

23 Claims, 6 Drawing Sheets

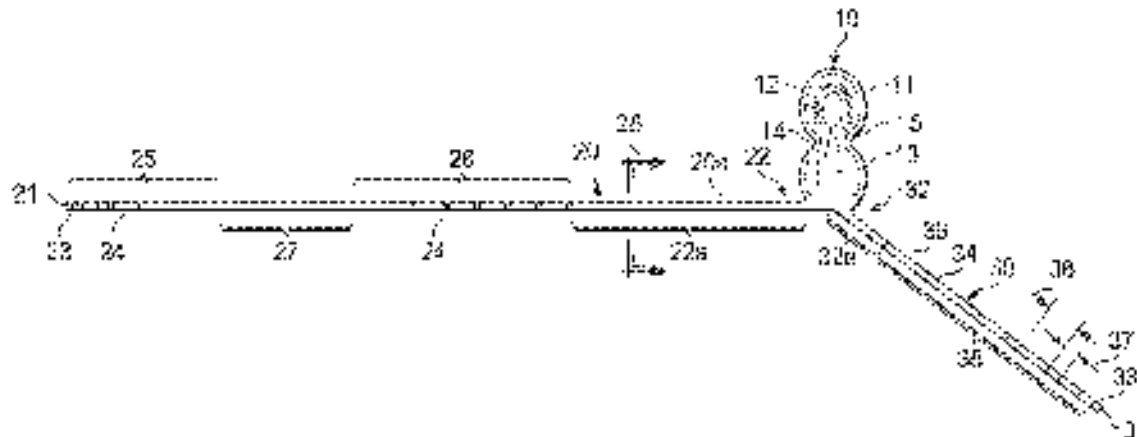

(56)

References Cited

U.S. PATENT DOCUMENTS

7,437,197	B2	10/2008	Harris et al.		
7,499,755	B2	3/2009	Cross, Jr.		
7,729,781	B2	6/2010	Swoyer et al.		
7,769,461	B2	8/2010	Whitehurst et al.		
7,894,905	B2	2/2011	Pless et al.		
8,140,152	B2	3/2012	John et al.		
8,412,334	B2	4/2013	Whitehurst et al.		
8,504,163	B1	8/2013	Meadows		
8,509,876	B2	8/2013	Karmarkar		
8,543,212	B2	9/2013	Merfeld et al.		
8,718,779	B2	5/2014	Whitehurst et al.		
2002/0116042	A1	8/2002	Boling		
2005/0102006	A1	5/2005	Whitehurst et al.		
2005/0209667	A1	9/2005	Erickson et al.		
2006/0241717	A1	10/2006	Whitehurst et al.		
2006/0293723	A1*	12/2006	Whitehurst et al.	607/48
2007/0112404	A1	5/2007	Mann et al.		
2007/0203545	A1	8/2007	Stone et al.		
2010/0274313	A1*	10/2010	Boling et al.	607/46
2010/0331922	A1*	12/2010	DiGiore et al.	...	607/62
2011/0093047	A1	4/2011	Davis et al.		
2011/0112603	A1	5/2011	Degiorgio et al.		
2011/0172736	A1	7/2011	Gefen et al.		
2013/0085542	A1*	4/2013	Mashiach	607/42
2013/0085561	A1	4/2013	Mashiach		
2013/0238067	A1	9/2013	Baudino		
2014/0142669	A1	5/2014	Cook et al.		

OTHER PUBLICATIONS

Goadsby PJ and Sprenger T. Current practice and future directions in the prevention and acute management of migraine. *The Lancet Neurology*. 2010; 9: 285-98.

Dodick DW. Occipital nerve stimulation for chronic cluster headache. *Advanced Studies in Medicine*. 2003; 3: S569-S71.

Saper JR, Dodick DW, Silberstein SD, McCarville S, Sun M and Goadsby PJ. Occipital nerve stimulation for the treatment of intrac-

table chronic migraine headache: ONSTIM feasibility study. *Cephalalgia: an international journal of headache*. 2011; 31: 271-85.

Silberstein S, Dodick DW, Reed KL, et al. Safety and efficacy of peripheral nerve stimulation of the occipital nerves for the management of chronic migraine: Results from a randomized, multicenter, double-blinded, controlled study. *Cephalalgia: an international journal of headache*. 2012.

Slavin KV, Colpan ME, Munawar N, Wess C and Nersesyan H. Trigeminal and occipital peripheral nerve stimulation for craniofacial pain: a single-institution experience and review of the literature. *Neurosurgical focus*. 2006; 21: E5.

Schwedt TJ, Dodick DW, Hentz J, Trentman TL and Zimmerman RS. Occipital nerve stimulation for chronic headache—long-term safety and efficacy. *Cephalalgia: an international journal of headache*. 2007; 27: 153-7.

Reed KL, Black SB, Banta CJ, 2nd and Will KR. Combined occipital and supraorbital neurostimulation for the treatment of chronic migraine headaches: initial experience. *Cephalalgia: an international journal of headache*. 2010; 30: 260-71.

Reed KL, Will KR, Chapman J and Richter E. Combined occipital and supraorbital neurostimulation for chronic migraine headaches: an extended case series [abst]. 15th Congress of the International Headache Society. Berlin, Germany: *Cephalalgia*, 2011, p. 98-9.

Lipton RB, Goadsby PJ, Cady RK, et al. PRISM study: occipital nerve stimulation for treatment-refractory migraine (p abs). *Cephalalgia: an international journal of headache*. 2009; 29: 30.

Reed KL. Peripheral neuromodulation and headaches: history, clinical approach, and considerations on underlying mechanisms. *Current pain and headache reports*. 2012; 17: 25-35.

Mueller M, Gaul C, Katsarava Z, Diener HC, Sure U and Gasser T. Occipital nerve stimulation for the treatment of chronic cluster headache—lessons learned from 18 months experience. *Central European neurosurgery*. 2011; 72: 84-9.

PCT: International Search Report and Written Opinion of PCT/US14/51235 (related application); Feb. 19, 2015; 24 pgs.

* cited by examiner

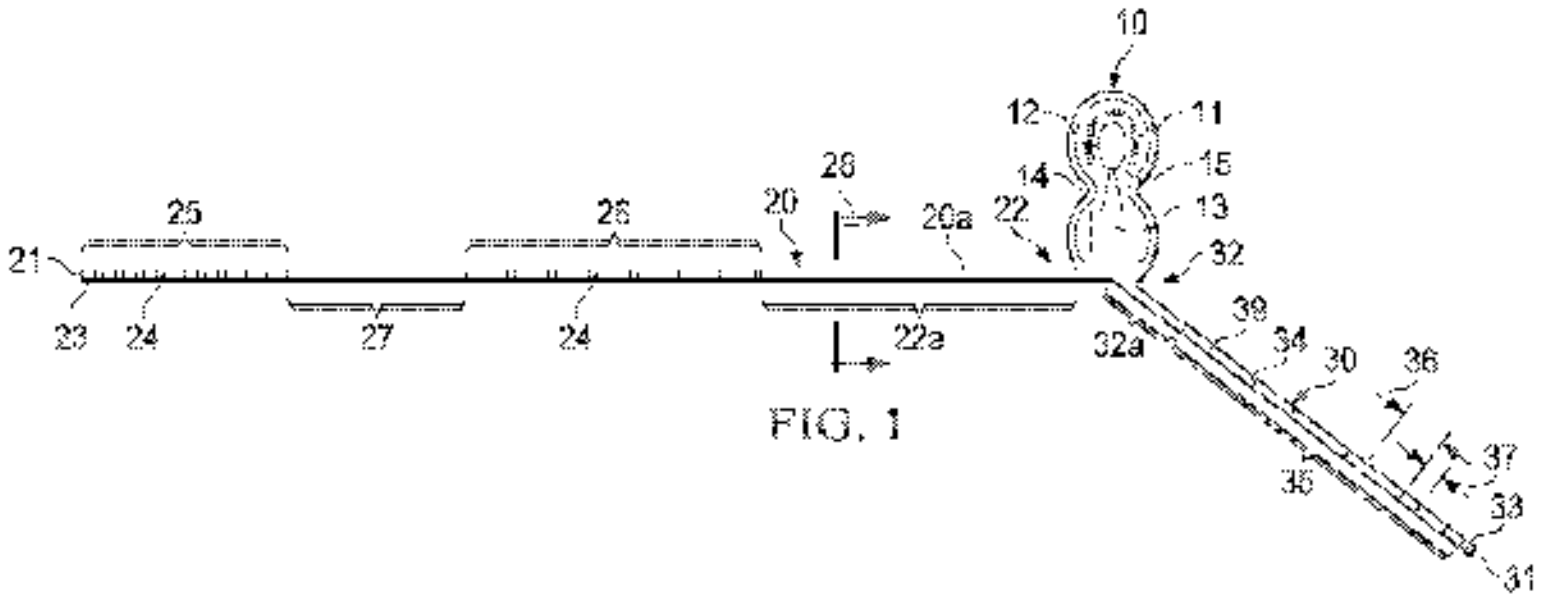

FIG. 1

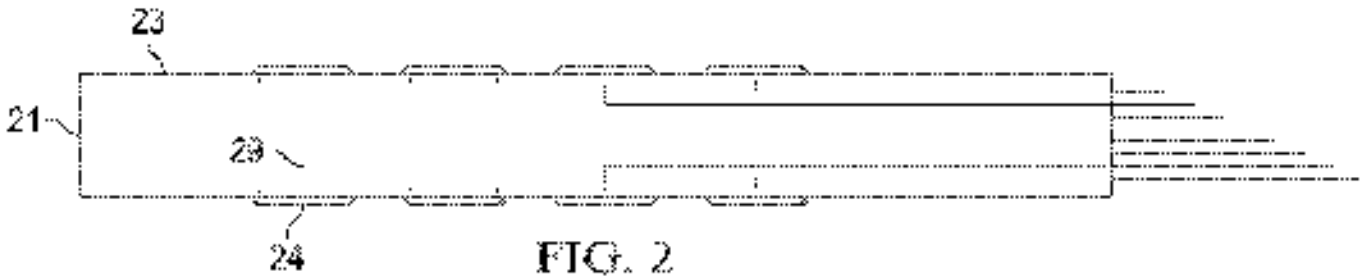

FIG. 2

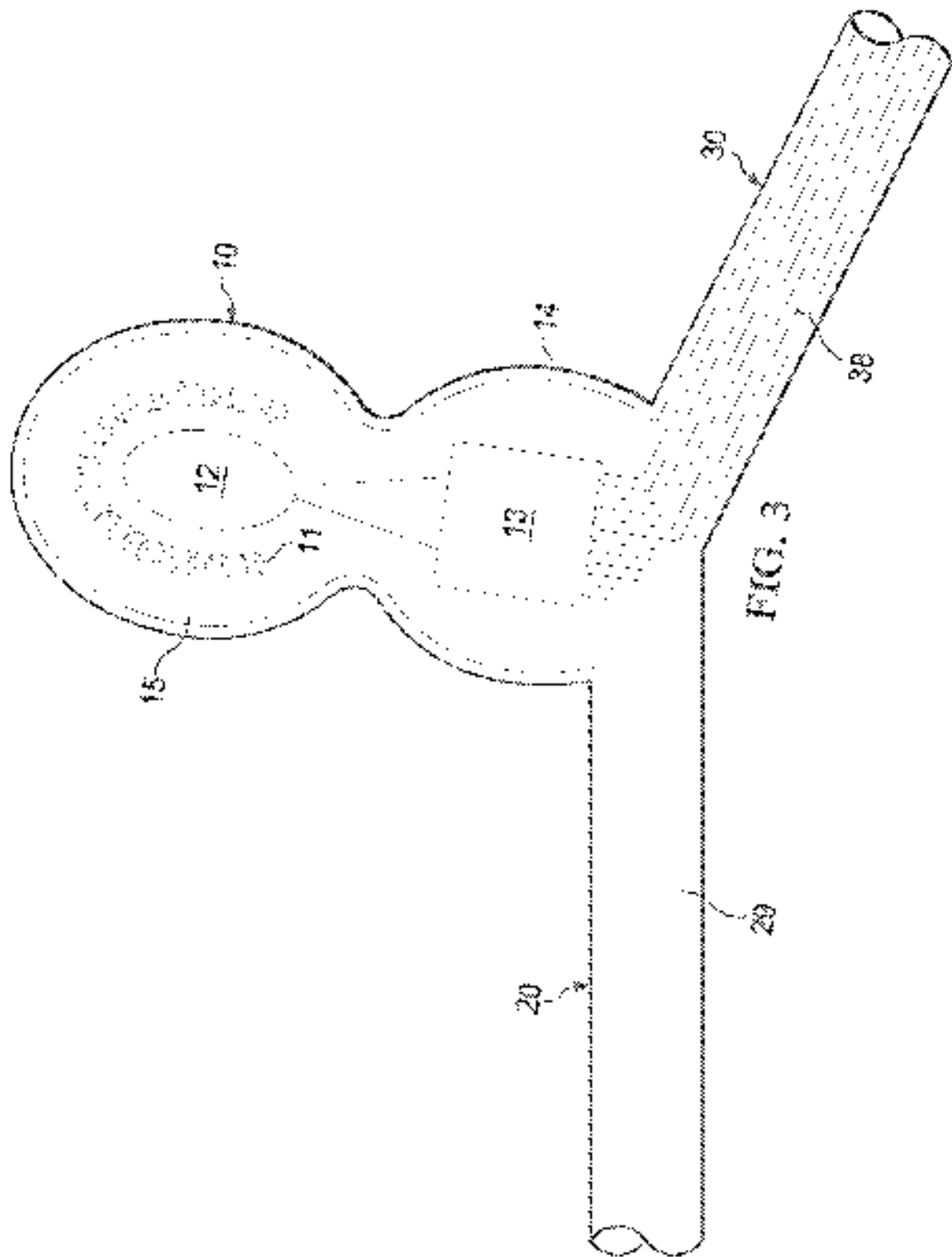
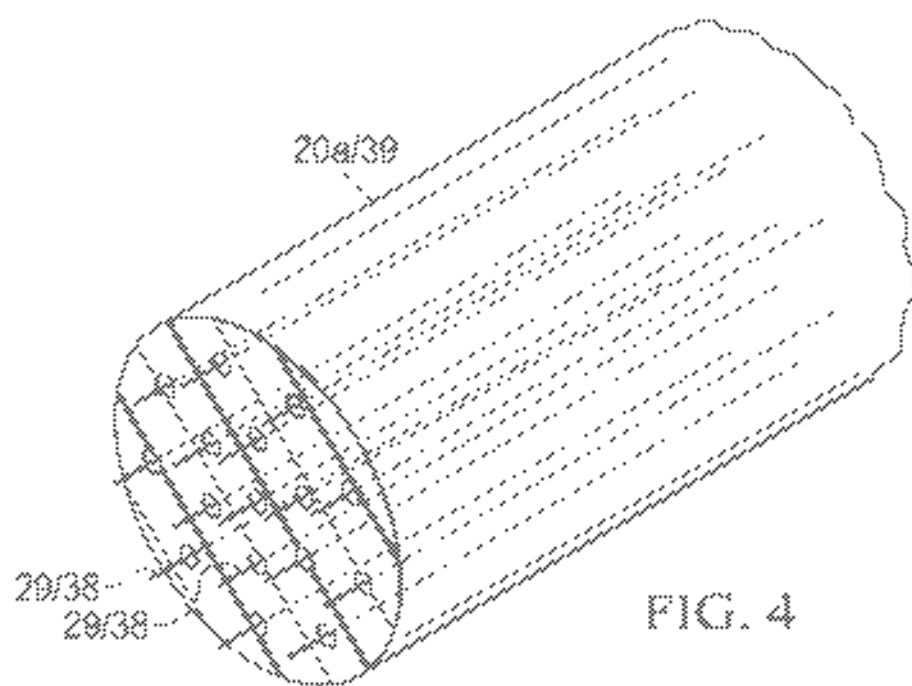

FIG. 3



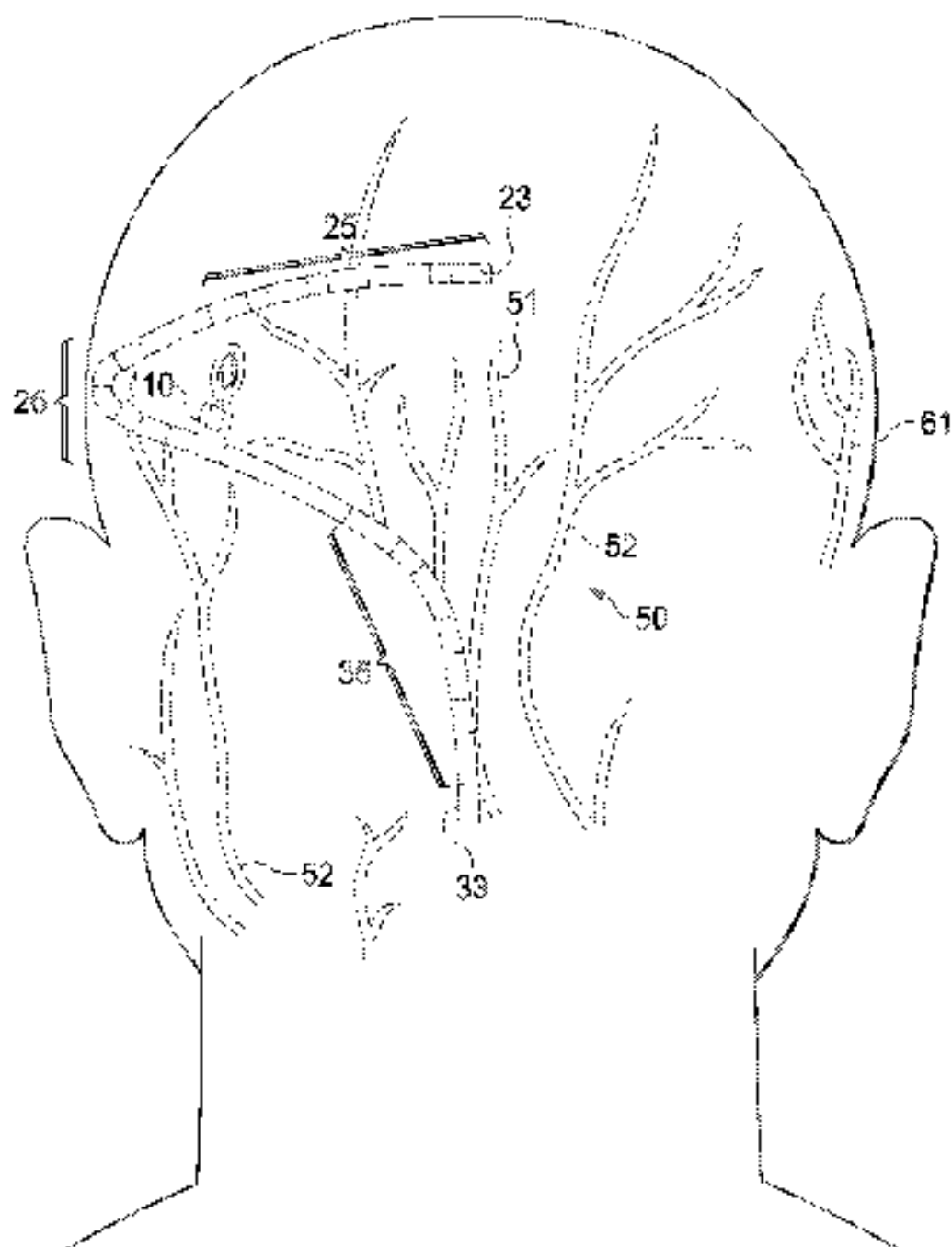

FIG. 5

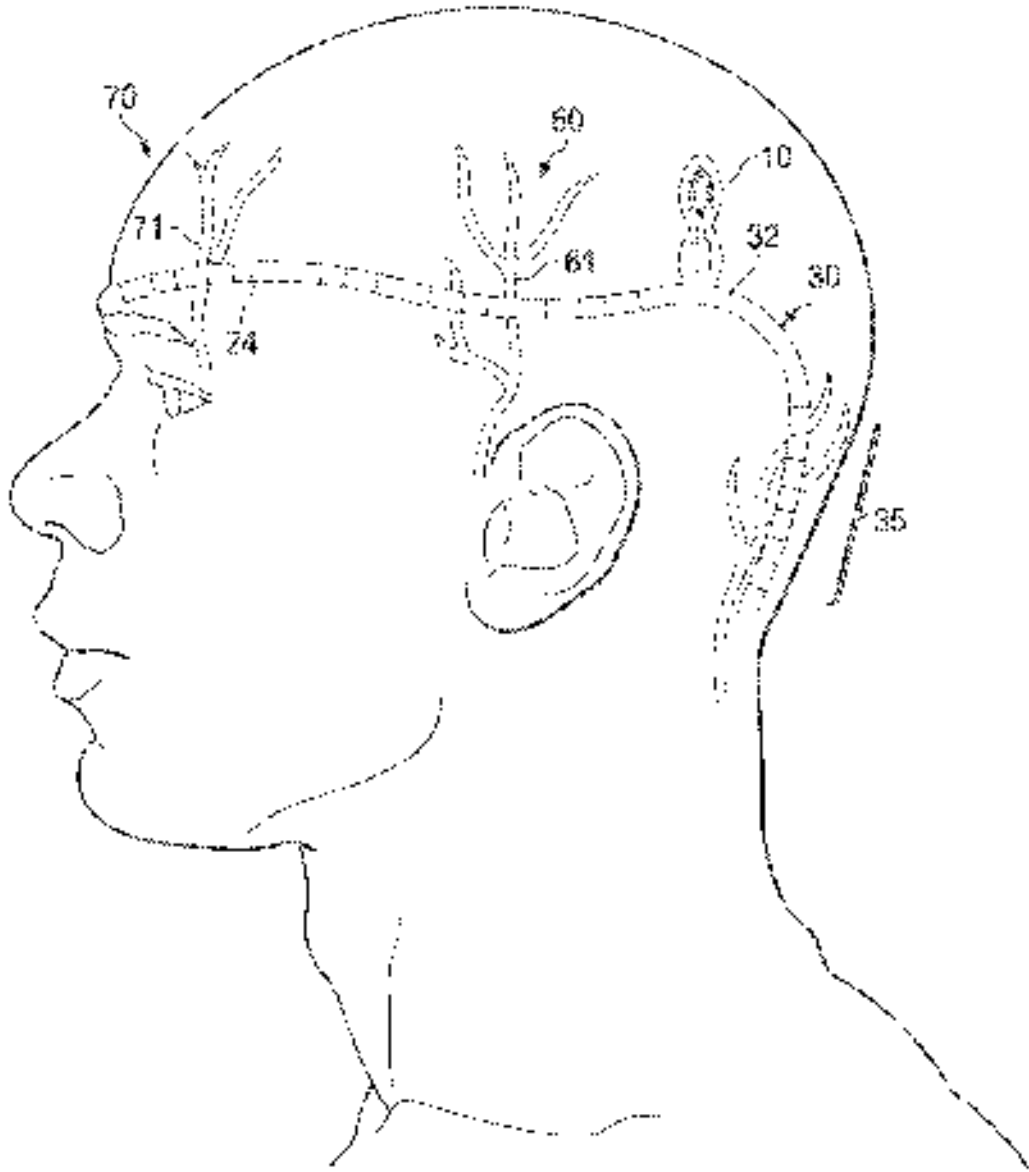

FIG. 6

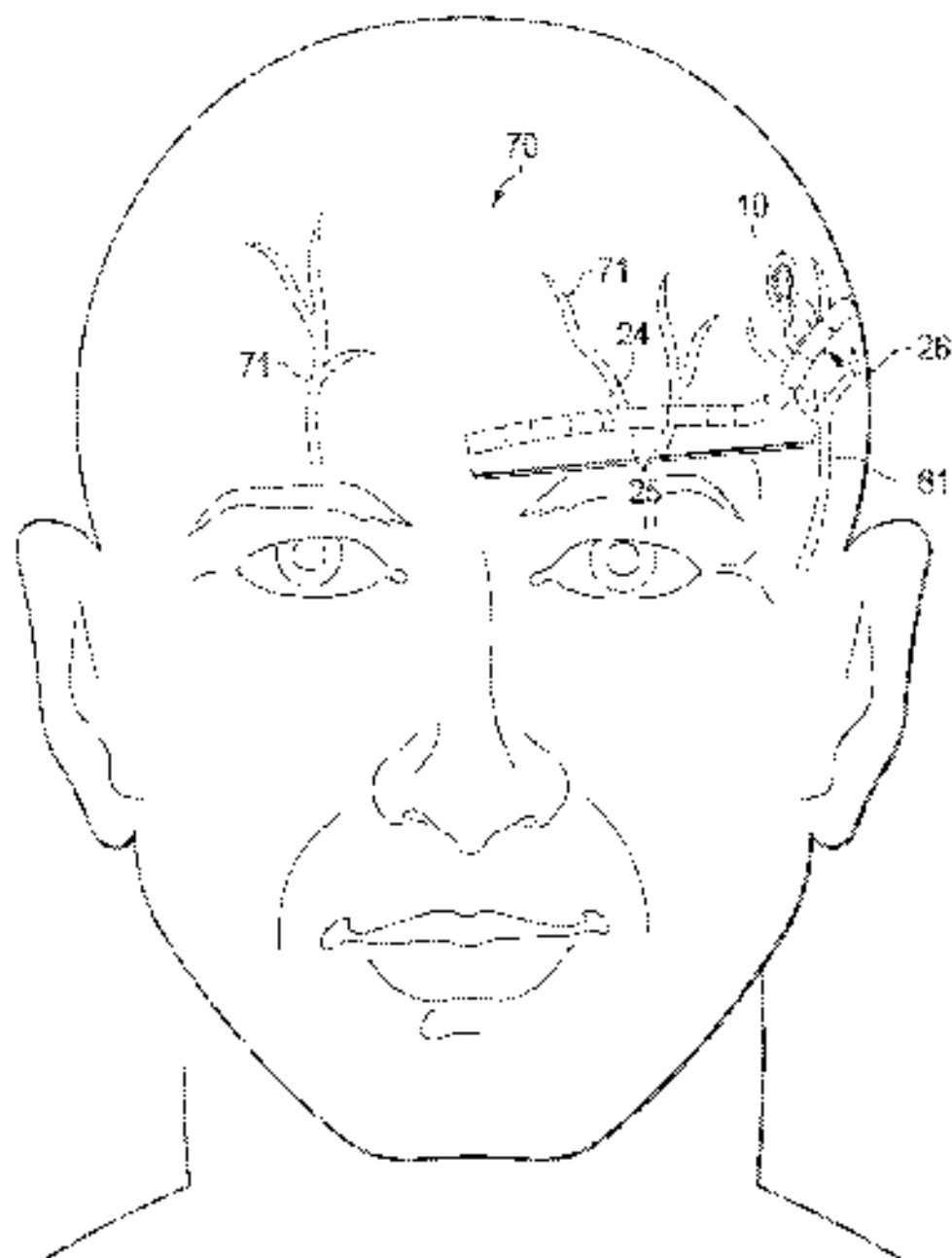

FIG. 7

1 IMPLANTABLE HEAD MOUNTED NEUROSTIMULATION SYSTEM FOR HEAD PAIN

CROSS-REFERENCE TO RELATED APPLICATIONS

This application claims benefit of U.S. Provisional Application No. 61/894,795, filed Oct. 23, 2013, entitled IMPLANTABLE HEAD MOUNTED NEUROSTIMULATION SYSTEM FOR HEAD PAIN, the specification of which is incorporated by reference herein in its entirety. This application is related to U.S. patent application Ser. No. 14/430,111, filed on area date herewith, entitled IMPLANTABLE NEUROSTIMULATION LEAD FOR HEAD PAIN, which claims benefit of U.S. Provisional Application No. 61/835,893, filed Aug. 14, 2013, the specification of which is incorporated by reference herein in its entirety.

TECHNICAL FIELD

The present disclosure relates generally to a fully head mountable implantable neurostimulation system and methods of treating migraine headaches and other forms of chronic head pain.

BACKGROUND

Neurostimulation systems comprising implantable neurostimulation leads are used to treat chronic pain. Conventional implantable peripheral neurostimulation leads are designed for placement in the spinal canal as part of a spinal cord stimulation system, and for the therapeutic purpose of treating various forms of chronic back and extremity pain.

SUMMARY

In various implementations, an implantable head-mounted, unitary peripheral nerve stimulator system may be configured for implantation of substantially all electronics, including an optional battery, at or near the implanted electrodes on the skull. The system may include an implantable pulse generator (IPG) from which two neurostimulating leads may extend a length sufficient to provide therapeutic neurostimulation unilaterally over the frontal, parietal and occipital regions of the hemisphere. The system may be operable to provide medically acceptable therapeutic neurostimulation to multiple regions of the head, including the frontal, parietal and occipital regions of the hemisphere, substantially simultaneously.

Each of the leads may include an extended, and body, a plurality of surface metal electrodes disposed along the lead body, which may be divided into two or more electrode arrays, and a plurality of inner, electrically conducting metal wires running along at least a portion of the length of the lead body and individually connecting an internal circuit of the IPG to individual surface metal electrodes. The extended lead body may comprise a medical grade plastic. The IPG may include a rechargeable battery, a control circuit, and an application specific integrated circuit (ASIC). The IPG may be configured for functionally connecting with an external radiofrequency unit. The external radiofrequency unit may be operable to perform various functions including recharging the rechargeable battery, diagnosing and evaluating the IPG, and programming the IPG.

Implementations may include one or more of the following features. The IPG may be of imperceptible ratio with respect

2

to the specific site of intended implantation in the head, such as an area posterior to and/or inferior to the ear. The system may be an external portable programming unit that is capable of delivering a radiofrequency couple to the implanted IPG. The IPG may have a rechargeable battery as a power source. The rechargeable battery may be inductively recharged through the skin.

Implementations may include one or more of the following features. A neurostimulating lead may not include a control channel for a stylet. A neurostimulating lead may have a smaller diameter than conventional leads.

Implementations may include one or more of the following features. The system may include the disposition of a sufficient plurality of surface electrodes over a sufficient linear distance along the neurostimulating leads to enable medically adequate therapeutic stimulation across multiple regions of the head, including the frontal, parietal, and occipital regions of the hemisphere, substantially simultaneously. The extended array of surface electrodes may be divided into two or more discrete terminal surface electrode arrays. The linear layout of the multiple surface electrode arrays may include at least one array positioned over the frontal region, at least one array positioned over the parietal region, and at least one array positioned over the occipital region.

Specific inter-array design features may include variations in the specific arrangement of electrodes within each of the arrays, the slope of the electrodes, e.g., whether the electrodes are cylindrical or flattened, the width of each electrode within each array, and the linear distance in events of separation of the electrodes within each array.

Various implementations may include a plurality of connection ports that can be connected with a plurality of leads and thus allow for attaching additional leads.

In various implementations, the body of treating chronic pain may include methods of treating various head and/or face pain conditions and/or other primary headaches, including cluster headaches, hemispheric, occipital, occipital, tension type headaches, chronic daily headaches, and/or including secondary headaches, such as cervicogenic headaches and other secondary musculoskeletal headaches.

In various implementations, methods of treating chronic pain may include methods of treating head and/or face pain of multiple etiologies, including neuropathic head and/or face pain, nociceptive head and/or face pain, and/or sympathetic related head and/or face pain.

In various implementations, the body of treating chronic pain may include methods of treating head and/or face pain of multiple etiologies, including greater occipital neuralgia, as well as the other various occipital neuralgias, supraorbital neuralgia, auricular temporal neuralgia, infraorbital neuralgia, and a trigeminal neuralgias, and other head and face neuralgias.

The details of one or more implementations are set forth in the accompanying drawings and the description below. Other features, objects, and advantages of the implementations will be apparent from the description and drawings.

BRIEF DESCRIPTION OF THE DRAWINGS

For a more complete understanding of this disclosure and its features, reference is now made to the following description, taken in conjunction with the accompanying drawings, in which:

FIG. 1 depicts a side view of a head-mounted, unitary neurostimulation system for migraine and other head pain. The system features an implantable pulse generator (IPG) from

which two neurostimulating leads extend from a Frontal-Parietal Lead (FPL) and/or Occipital Lead (OL), each one includes a plurality of electrodes in a distribution and over a length to allow full unilateral coverage of the frontal, parietal, and occipital portions of the head.

FIG. 2 depicts a side view of a Frontal-Electrode Array (FEA) with Internal Wires. The FEA is disposed over the distal portion (such as E10) of the FPL, which a neurosurgeon places it over the frontal region, and specifically over the supraorbital nerve and other adjacent nerves of the region. In general the layout, disposition and connections of the Internal Wires and Surface Electrodes disposed over the Parietal Electrode Array (PEA) and the Occipital Electrode Array (OEA) are the same as that depicted for the FEA.

FIG. 3 depicts a side view of the Internal Wires exiting over the IPG's Internal Circuitry to the Surface Electrodes disposed over the FPL and the OL.

FIG. 4 depicts a cross-sectional view of a Lead Central Body comprising a Cylindrical Lead Body (with Internal Wires) between the IPG's Internal Circuitry and the Lead Surface Electrodes.

FIG. 5 depicts a rear view of a Head with a full Head-Mounted Neurostimulator System In-Situ. Prominent here is the OL (epiplex) passing from the IPG caudally and medially across the occipital region, whereby the OEA is disposed in a distribution to cross over and cover the major associated nerves, primarily the greater occipital nerve, but typically including the lesser and/or third occipital nerve as well. Also depicted are the PEA and the FEA of the FPL as they cross and cover the primary nerves of the Parietal Region, including the auriculo-temporal nerve, and the Frontal Region, including the supraorbital nerve.

FIG. 6 depicts a side view of a Head with a full Head-Mounted Neurostimulator System In-Situ. Prominent here is the PEA, as it covers a portion of the Parietal Region and the major associated nerves, including the auriculo-temporal nerve, as well as adjacent cutaneous nerves. Also depicted are the courses of the distal portion of the FPL and the OL as they pass over and cover the associated nerves of the Frontal (Supraorbital) and Occipital Regions.

FIG. 7 depicts a front view of a Head with a full Head-Mounted Neurostimulator System In-Situ. Prominent here is the FEA, as it covers a portion of the Frontal (Supraorbital) Region and the major associated nerves, primarily the supraorbital nerve, but also commonly the greater trochlear nerve, as well as adjacent nerves. Also depicted is the course of the parietal portion of the FPL.

INDEX OF REFERENCE

- 10: Implantable Pulse Generator
- 11: Antrum
- 12: Battery
- 13: Application Specific Integrated Circuit
- 14: Medical Plastic Cover
- 20: Frontal-Parietal Lead
- 21a: Plastic Body Member
- 21: Distal Lead
- 22: Proximal Lead
- 22a: Proximal Lead Segment
- 23: Distal Non-Stimulating Tip
- 24: Surface Metal Electrode
- 25: Frontal Electrode Array
- 26: Area Electrode Array
- 27: Laser-Array Interval
- 28: Part of Cross Section of Lead
- 29: Lead Internal Wire

- 30: Occipital Lead
- 31: Distal End
- 32: Proximal End
- 32a: Proximal Lead Segment
- 33: Distal Non-Stimulating Tip
- 34: Surface Metal Electrode
- 35: Distal Electrode Array
- 36: Area Electrode Array
- 37: Surface Electrode Width
- 38: Lead Internal Wire
- 39: Plastic Body Member
- 50: Distal Region of Head
- 51: Greater Occipital Nerve
- 52: Lesser Occipital Nerve
- 53: Third Occipital Nerve
- 60: Parietal Region of Head
- 61: Auriculo-temporal Nerve
- 70: Frontal Region of Head
- 71: Supraorbital Nerve

DETAILED DESCRIPTION

Referring now to the drawings, wherein like reference numerals are used herein to designate like elements, throughout the various views and embodiments of implantable head-mounted neurostimulator system for head pain are illustrated and described, and other possible embodiments are described. The figures are not necessarily drawn to scale, and, in certain instances the drawings have been exaggerated and/or simplified in places for illustrative purposes only. One of ordinary skill in the art will appreciate the many possible applications and variations based on the following examples of possible embodiments.

A. Introduction

The present disclosure provides a fully head-mounted, implantable, peripneural neurostimulation system developed for the treatment of chronic head pain. It incorporates multiple elements and features that take into account the unique anatomic, physiologic, and other related challenges of treating head pain with implantable neurostimulation, thereby greatly improving on therapeutic response, patient safety, medical efficacy, and medical costs, which combine to improve overall patient satisfaction.

Prior to implantable peripheral neurostimulation systems and components, including leads and pulse generators, have been designed and developed specifically as spinal cord stimulator systems and, for the specific therapeutic purpose of treating chronic back and extremity pain. Over the years, these spinal cord stimulators were ultimately accepted and adapted for use as implantable peripheral nerve stimulators for the treatment of migraine headaches, and other forms of chronic head pain; however, they were so utilized with full recognition of the inherent risks and limitations given that they were developed only to address, and accommodate to, the unique anatomic and physiologic features of the back and chronic back pain.

U.S. Provisional Patent Application Ser. No. 61/866,893 describes the many old problems associated with the application of spinal cord stimulators for head pain, as fundamentally, these design flaws associated with, and inherent to, the use of an implantable therapeutic device in an area of the body that it was not designed for.

Indeed, the anatomy of the head, and the anthropophysiology of headaches, and other forms of head pain, are so significantly different from the anatomy of the spinal cord, and pathophysiology of chronic back pain, that when spinal cord stimulators are utilized for cranial implants, the clinical problems associated with these different systems often themselves

Importantly, these well-documented problems are clinically very significant and include issues of patient safety and satisfaction, the risk of an inadequate, or suboptimal, therapeutic response, and issues with patient comfort and cosmetics, as well as a recognized increased risk of surgical complications and technical problems.

These medical issues stem from the design of conventional leads and the 100% conventional lead design include a relatively large diameter cylindrical shape, (a) an inadequate length and the necessity of implanting the IPG in the torso and distant from the distal leads, and a number and disposition of the surface electrodes and active lead arrays that do not match the requirements. A cylindrical end of relatively large diameter results in increased pressure on, and irritation, cutting of, the underlying skin, particularly of the forehead. Because conventional leads are of moderate length to extend from the lead to the IPG implant site, commonly in the lower back, abdomen, or gluteal region, lead extensions are often employed, and there are attendant risks of infection, local discomfort, and cosmetic concerns.

With respect to prior leads, there is only a single array of electrodes, with common lead options including 4, 8, or 12 electrodes disposed over that single array; 2) The array is relatively short with most leads having an array of from 5-7.2 cm in length; 3) Within this single array, the individual electrodes are disposed in parallel with non-equal inter-electrode distances. This results in the need to implant multiple (often four or more) of the conventional leads to adequately cover the painful regions of the head.

There are several potential clinical outcomes that result from the use of one lead for the treatment of chronic head pain. First, since they comprise a single, relatively short active array, the currently available leads provide therapeutic stimulation to only a single region of the head; that is, they can provide stimulation to only the frontal region, or a portion of the parietal region, or a portion of the occipital region. Therefore, if a patient has pain that extends over multiple regions, then multiple separate lead implants are required (basically one lead implant is required for each unit and region). A great majority of patients with chronic headaches experience holicephalic pain that is, they experience pain over the frontal and parietal and occipital regions bilaterally. Therefore, commonly these patients will need 4 to 7 leads implanted to achieve adequate therapeutic results (2 or 3 leads on each side).

Second, the need for multiple leads incurs considerable added expense, and more importantly, added medical risk associated with a series of events attendant to the multiple surgical procedures. Such adverse events include an increased risk of infection, bleeding, and residual issues with the leads, e.g., lead fracture, lead migration, and local irritation.

Third, as has been discussed above, the in vivo electrode spacing may be of central therapeutic significance. That is, for example, whereas commonly pain over the occipital region is consistently effectively treated by quadripolar leads (leads with four evenly spaced electrodes) that have the electrodes relatively widely spaced apart (approximately 2 cm or more apart), clinically it is often found that electrodes configurations that are more narrowly spaced may be more effective over the supraorbital nerve and regions. Thus, a quadripolar lead that has the electrodes only 1-2 cm apart may be more effective in this region, as it allows for more precise control of the delivered electrical pulse wave delivery.

Inter-electrode spacing is a so of therapeutic significance. For example, whereas pain over the occipital region is commonly treated effectively by systems incorporating relatively widely-spaced quadripolar leads (four electrodes at approxi-

mately 2 cm or more intervals), more narrowly spaced contacts are often more effective over the supraorbital region.

When an IPG system, designed for cranial nerve stimulation systems is employed as a peripheral nerve stimulator for head pain, several outcomes result. First, the IPG is implanted at a considerable anatomic distance from the neural lead implants. Indeed, the leads must pass from their distal cranial implant positions across the cervical region and upper neck to the IPG implant location, which are most commonly in the lower back, lower abdomen, or gluteal region. The leads must cross multiple anatomic motion segments, including the neck and upper back and/or chest at a minimum, and commonly include the mid neck, lower back and waist segments, as well. The simple motions of normal daily life produce adverse tension and torque forces on the leads across these motion segments, which in turn increases the risk of various outcomes, including lead migration and/or lead fracture. In addition, the relatively large size of a spinal cord stimulator IPG contributes to local discomfort, cosmetic concerns, and increased risk of infection that may become larger and harder to treat in comparison to the size of the IPG pocket.

The greatest disclosure is directed to an implantable lead-mounted, on-body peripheral neuromodulation system that includes an IPG from which two neural stimulating leads extend to a length sufficient to allow for therapeutic neuromodulation, bilaterally over the frontal, parietal and occipital regions of the head.

The present disclosure addresses and effectively solves problems attendant to currently available leads. The most important of these is the fact that current leads can only adequately stimulate single regions of the head and to design elegant flaws associated with current surface electrode number and disposition. The disclosure additionally addresses and solves other problems inherent with the currently available leads, including problems with cosmetics and patient comfort, particularly over the frontal regions, due to the uncomfortable pressure placed on the skin of the forehead, due to the cylindrical shape and relatively large diameter of the distal portion of the lead. Finally, the lead of the present disclosure solves the currently available leads' problem of inadequate lead length to reach a placed location of the implantable pulse generator, which therefore necessitates the additional risk and expense of further surgery to implant lead extensions.

In one aspect, the implantable, head-mounted, neuromodulation system of the present disclosure is for implantation in the head, and to provide neuromodulation therapy for chronic head pain, including chronic head pain caused by migraine and/or headaches, as well as chronic head pain due other etiologies. The peripheral neuromodulation system disclosed herein takes into account unique anatomic features of the human head, as well as the unique, or singular, features of the various pathologies that give rise to head pain, including migraine and/or headaches, as well as other forms of chronic head pain. To date, all commercially available systems that have been clinically utilized, for implantation as a peripheral neuromodulation system were actually originally designed specifically for placement in the cranial space, as part of a cranial nerve stimulation system, for the therapeutic purpose of treating chronic back and/or extremity pain. Thus, there are currently no commercially available leads to complete system that have designs in the public domain, that have been designed and developed for use in the head and forehead pain.

In another aspect, the implantable, lead-mounted, neuromodulation system for head pain comprises multiple design features, including disposition of a sufficient plurality of sur-

use electrode over a sufficient linear distance along the distal lead such as with a thin lead that is a single lead is capable of providing medically adequate therapeutic stimulation over the entire hemisphere that is, over the frontal, parietal, and occipital region substantially simultaneously. Currently available systems, which were designed specifically for epidural placement for chronic back pain, are capable of only providing stimulation over a single region that is over either the frontal region alone, or the parietal region alone, or the occipital region alone.

In yet another aspect, the implantable, head-mounted, neurostimulation system for head pain comprises multiple design features, including the physical grouping of the extended array of surface electrodes into three or more discrete terminal surface electrode arrays. The linear layout of these two or more (preferably three or more) surface electrode arrays is designed such that following implantation there would be at least one array positioned over the frontal region, at least one array positioned over the parietal region, and at least one array positioned over the occipital region. This feature further improves upon the therapeutic effectiveness of the extended terminal surface electrode array sufficient for hemispherical stimulation by allowing for more precise control of the therapeutic neurostimulation parameters.

In still another aspect, the implantable, head-mounted, neurostimulation system for head pain comprises multiple design features, including incorporating individual design features within each of the three or more individual surface electrode arrays; examples of such intra-array design features would include the specific number of electrodes allotted to each group; whether the electrodes are cylindrical or flattened, the width of each electrode within each array, and the linear distance intervals of separation of the electrodes within each array. This feature further improves upon the therapeutic effectiveness of the extended terminal surface electrode array sufficient for hemispherical stimulation, and the grouping of these electrodes into three or more separate surface electrode arrays, by providing each specific array location a unique intra-array design that takes into account, and thereby seeks to optimize, design elements that are known to be possibly or likely beneficial to the therapeutic end result, given the anticipated non-implantation specific location of that array.

In yet another aspect, the implantable, head-mounted, neurostimulation system for head pain comprises a linear novel design features, including incorporating individual design features into a single lead design and thereby achieving additive benefits.

In still another aspect, an implantable, head-mounted, neurostimulation system for head pain results in a marked decrease in the number of separate lead implants required to adequately treat a single patient. A single implant will provide the same therapeutic coverage that it would take the implantation of three or four of the currently available leads; that is, instead of the current standard of calls for three or more leads to be implanted to provide adequate hemispherical coverage, the same anatomical region may be covered with a single stimulator lead implant. The lead provides extensive coverage over the full hemisphere that is achieving medically acceptable neurostimulation unilaterally over the frontal, parietal, and occipital regions simultaneously. In contrast, publicly known leads are able to consistently provide medically acceptable neurostimulation therapy only over a single region; meaning that it would require three separate surgically placed lead implants to achieve the same therapeutic coverage of a single implant of a level of therapeutic disclos-

sure. This will decrease the total number of surgeries required, as well as the cost of each individual surgery for many patients.

In another aspect, the present disclosure is directed to a system that is fully addressed to the need, which obviates the requirement of currently available systems of having long leads and extensions extending across the neck and back to LVI locations or merely in the low back and pleural region, and thereby decreases the physical problems attendant to such long leads and extensions, including discomfort, infection, terminal extension issues such as the injury and other morbidities. This ultimately results in a decreased number of surgeries required by a patient.

In other aspects the system may include one or more of the following features. A neurostimulating lead may not require a central channel for a stylet. A neurostimulating lead may have a smaller diameter than currently available leads.

In other aspects the system may include one or more of the following features. The system may include the horizontal position of a sufficient quantity of surface electrodes over a sufficient linear distance along the system's leads to enable medically adequate therapeutic stimulation across multiple regions of the head, and preferably the entire hemisphere, that is, over the frontal, parietal, and occipital region simultaneously. The extended array of surface electrodes may be divided into two or more discrete terminal surface electrode arrays. The preferred linear layout of these multiple surface electrode arrays includes at least one array positioned over the frontal region, at least one array positioned over the parietal region, and at least one array positioned over the occipital region.

In other aspects intra-array design features may include variations in the specific number of electrodes allotted to each group; the shape of the electrodes, e.g., whether the electrodes are cylindrical or flattened; the width of each electrode or surface electrode width within each array; and the linear distance intervals of separation of the electrodes or inter electrode distance within each array.

In other aspects, the system may a plurality of connection ports that can be connected with multiple leads, and thus allow for attaching additional leads should they later be required.

In another aspect, an implantable, head-mounted, neurostimulation system for head pain comprises multiple design features, including incorporating individual design features by improving the incidence of adverse events, including the risk of infection, as well as the risk and incidence of other terminal morbidities associated with implantation, including lead migration and lead fracture, amongst others. The system comprises two or more (i.e., three or more) surface electrode arrays, cohesively designed, that are disposed over a sufficient lead length to allow for medically acceptable hemispherical neurostimulation coverage of at least systems with the supraorbital, parietal, and occipital cranial regions. To achieve the same clinical coverage from a single implant, it would require three or more separately surgically implanted leads. Therefore, by reducing the number of surgical incisions, as well as the number of surgically implanted leads, the associated risks of adverse events are proportionately diminished.

In yet another aspect, an implantable, head-mounted, neurostimulation system for head pain may treat various head and/or face pain of multiple etiologies, including migraine headaches and other primary headaches, including cluster headaches, hemisphere contrain headaches, tension type headaches, chronic daily headaches, transformed migraine headaches, further including secondary headaches, such as cervicogenic headaches and other secondary or noscogenic of

headaches including neuropathic head/neck and pain, nociceptive head/neck pain, and/or sympathetic related head/neck pain; including greater occipital neuropathy, as well as the other various occipital neuropathies, supraorbital neuralgia, auriculotemporal neuralgia, infraorbital neuralgia, and other trigeminal neuralgia, and other neck and face neuralgia.

In other aspects, an implantable, head-mounted, neuro-stimulation system for head pain may not require a central channel for stylet placement over its distal (frontal) portions. The lead may improve patient comfort and cosmetics by virtue of its relatively small diameter over the distal portions of the lead, partially due to the inclusion of central stylet channel, as well as due to a progressive decrease in the number of internal wires containing galter each terminal electrode. The lead may further improve cosmetic appearance in a patient condition by incorporating a lathe-turned lead design for that portion of the lead expected to be over the frontal portion of the head.

Thus the present disclosure provides for a peripheral neuro-stimulation lead that is uniquely designed for implantation in the head as a therapy for chronic head pain, and is designed to solve the known design issues associated with current leads, as the lead of the present disclosure seeks to minimize the therapeutic response, improve patient comfort, improve cosmetics, reduce the number of surgical leads required, reduce medication use, and reduce medical costs.

B. Overview

Turning now to the drawings, which depict the system and several of its components in various aspects and views, and in which similar reference numerals denote similar elements, the drawings illustrate an IPG from which two neurostimulating leads may extend to a length sufficient to allow for therapeutic neurostimulation unilaterally over the frontal, parietal and occipital regions. The leads include an external plastic lead body; a plurality of surface metal electrodes disposed along the lead, which may be divided in two or more electrode arrays; a plurality of internal electrically conducting metal wires running along at least a portion of the length and electrically connecting the IPG to internal, to individual surface metal electrodes. The implantable pulse generator includes a rechargeable battery, an antenna coil, and ASIC. The system may be operable to provide therapy by acceptable therapeutic neurostimulation to multiple regions of the head, including the frontal, parietal and occipital region simultaneously, and these figures demonstrate various views of this feature as the lead is depicted, in-situ.

C. Full and Mounted Neurostimulate System

FIG. 1 depicts a side view of a full neurostimulate system, which consists of an implantable pulse generator (IPG) 10 along with two unilaterally placed lead extensions: a Frontal-Parietal Lead (FPL) 20 and an Occipital Lead (OL) 30 of adequate length to extend roughly the midline of the Fore-lead end to the midline at the occipital junction, respectively.

FIGS. 5, 6 and 7 depict two different end view of views of the system, in-situ. The unit is demonstrated as an implant positioned where the IPG 10 is anterior and cephalic to the plane of the ear. The drawings demonstrate the FPL 20 passing over the parietal 60 and frontal 70 regions of the head in a manner that places the FPL over the supraorbital nerve 71 and the PEA over the distal (temporal) nerve 61. The OL 30 is shown passing unilaterally in a medial over the occipital region of the head 50 such that the OEA 35 cross over the greater occipital nerve 51, the lesser occipital nerve 52, and the third occipital nerve 53.

10. Frontal-Parietal Lead

Continuing with FIG. 1, the FPL as part of the unit-body construction, extends from the IPG. The FPL comprises a plastic body member 20a and a set of internal conducting wires 29.

The plastic body member 20a is an elongated, cylindrical, flexible member, which may be formed of a medical grade plastic polymer. It has a proximal end 22, a distal end 21, and may be longitudinally divided into five segments along its linear dimension. Progressing from the proximal end 22, these segments sequentially include a proximal lead segment (PLS) 22a, a parietal electrode array (PEA) 26, an inter-array channel 27, a frontal electrode array (FSA) 25, and a distal non-stimulating tip 23.

The lead internal wires 29 pass along the interior of the plastic body member as depicted in FIG. 4.

E. Frontal Electrode Array

Continuing with FIG. 1, the FSA 25 consists of a plurality of surface metal electrodes (SME) 24 uniformly disposed over a portion of the distal aspect of the FPL 20. Lead internal wires 29 connect to the SME 24 as depicted in FIG. 2, which represents the distal four SME 24 of the lead.

F. Parietal Electrode Array

Referring to FIG. 1, the PEA 26 consists of a plurality of SMEs 24 uniformly disposed along a linear portion of the FPL. The PEA 26 is separated along the FPL from the FSA by an inter-array channel 27. It is separated only the lead from the FSA by the PLS 22a. The lead internal wires 29 connect to the individual SME 24 of the PEA in the same fashion as the do with the SME of the FSA as shown in FIG. 2.

G. Occipital Lead

Continuing with FIG. 1, the occipital lead (OL) 30 as part of the unit-body construction, extends from the IPG 10. It comprises a plastic body member 39 and a set of lead internal wires 38 that pass through the outer cylinder of the lead to connect to a series of SME 34 that are uniformly disposed along a portion of the length of the lead. These lead internal wires 38 pass and connect in the same manner as described above for the SME 24 of the FSA as depicted in FIG. 2 and FIG. 4.

The plastic body member 39 is an elongated, cylindrical, flexible member, which may be formed of a medical grade plastic polymer. It has a proximal end 32 and a distal end 31. Progressing along the lead from the proximal end 32, these segments sequentially include a proximal lead segment (PLS) 32a, an occipital electrode array (OEA) 35, a distal non-stimulating tip 33.

H. Occipital Lead Array

As depicted in FIG. 1, the OEA 35 consists of a plurality of surface metal electrodes (SME) 34 uniformly disposed over a portion of the OL 30. Lead internal wires 38 connect to the SME 34 in the same fashion as depicted for the FSA as shown in FIG. 2.

I. Implantable Pulse Generator

Referring to FIG. 1 and FIG. 3, the three primary physical and functional components of the IPG 10 include a rechargeable battery 12, an antenna coil 14, and an application specific integrated circuit (ASIC) 13, along with the necessary internal wire connections amongst these related components, as well as to the incoming lead internal wires 29, 39. These individual components may be encased in a can made of a medical grade metal and plastic cover 14, which itself may sit atop the ceiling FPL 20 and OL 30.

C. Connections of Main Body and Sub-Elements

The system may include a unit-body construction to provide physical and functional continuity of the related components and sub-components.

The overall mechanical purpose of an implantable neuro-stimulation system is to generate and conduct a prescribed electrical pulse wave from an IPI 10 over a set of lead internal wires 29, 38 running a portion of the length of the lead to specified programmed set of SME 24, 34, whereby the current is then conducted by a semiconductor to an adjacent, or nearby, set of one or more SME 24, 34, which in turn passes the signal proximally down the lead wire 29, 38 back to the IPI 10 and to ASIC 13, thus completing the circuit.

I. First Embodiment

The first embodiment provides for a lead that incorporates one or more of the features outlined above and includes a head-mounted, or body neuro-stimulating system comprising an IPI 10 and at least two neurostimulating leads (PE 20 and OE 30). The system may be implanted in a manner such that the IPI 10 and two leads 20, 30 are disposed as illustrated in FIG. 5, FIG. 6 and FIG. 7. The IPI 10 is capable of mechanically connecting to and communicating with a portable programmer and an external power source for battery recharging.

In this embodiment, the leads are constructed as described above and as depicted in the drawings. The FPL 20 is approximately 29 cm in length from its proximal end 22 to its distal end 21. The PE 20 has a distal non-stimulating tip of approximately 3 cm in length that abuts the PIA, which may have ten SME 24 uniformly disposed over approximately 8 cm. This is followed by an inter-arry interval 27 of approximately 1 cm, then the PIA, which may include eight SME 24 uniformly disposed over approximately 6 cm, and finally a proximal lead segment 22a that ends at the proximal end 22, where the lead transitions to the IPI 10 and the lead internal wires 29, 38 connect to the ASIC 13.

In this embodiment, the occipital lead may comprise a plastic body member 30 over which six SME 34 may be disposed uniformly over approximately a 10 cm length of the lead, and the lead terminates in approximately a 3 cm distal non-stimulating tip 35.

In this embodiment, the IPI 10 comprises the elements described above and depicted in the drawings, including an ASIC 13, a rechargeable battery 12, and an antenna 11, which may be housed in a common interior 15 that may include a medical grade plastic case with plastic cover 14. In this embodiment, the dimensions of the IPI 10 measured along the rear surface of the plastic cover 14 may be approximately 5 cm by 5 cm by 0.5 cm.

The system includes a portable programmer and a portable recharging unit, both of which functionally couple to the IPI 10 through a radiofrequency mechanism.

In this embodiment, the system is capable of running a program from the portable programmer that includes such parameters as pulse amplitude, frequency and pulse width. **M. Alternate Embodiments**

There are multiple alternate embodiments that preserve the features of the neurostimulation system disclosed herein, which include an externally rechargeable and programmable, 20 cm sized and configured for implantation in the head, arm, arm which fronto-parietal and occipital leads, along with two respect surface metal electrode arrays, extend to cover multiple regions of the head in various embodiments, the spacing and dimensions of the electrode array(s) may be constant, or the electrode arrays may be specifically designed, with respect to electrode type, dimensions, and layout for improving the therapeutic effectiveness.

Thus, the disclosure comprises extended electrode array designs (two or more regions by a single lead), and/or multiple arrays and optimized arbitrary electrode disposition. The disclosure also comprises lead configurations, which

include the capability of a modifiable design that provides for ports on either the standard FPL and OLs. In another embodiment, the IPI receive additional separate leads, if it is necessary either at the time of initial implant or in the future.

Further, the lead lengths, along with the specific technical markings and dimensions of the individual surface metal electrodes and electrode arrays, may be varied to include more or less than three electrode regions on the head (occipital, parietal, and frontal) contemplated by the first embodiment. For example, a single IPI may energize and control multiple additional leads of varying lengths that ultimately could be disposed over virtually every region of the head and face bilaterally.

At least two electrodes may be included per region, and while the first embodiment calls for a total of 24 electrodes disposed over three arrays covering three different regions of the head (the occipital, parietal and frontal regions), there is no absolute limit on the maximum number of electrodes. Similarly, while the first embodiment calls for three electrode arrays, the disclosure contemplates two or fewer arrays may be used as the array covers at least two regions. There is also no limiting maximum for the number of arrays. Also, there may be multiple variations of design within each separate array, including for example, variations in the number, dimensions, shape, and metal composition of the individual electrodes, as well as the distance and consistency of distance between electrodes within each array. Further, each array may have the same or multiple of different designs.

While the neurostimulation system has been described for implantation as a peripheral neurostimulator in the head and for head pain, it is capable of being implanted and used as a peripheral nerve stimulator over other regions of the head and face (as described above) and also over other peripheral nerves in the body.

N. Operation

When functioning, that is when the internal circuit of lead internal wires is connected to an IPI, the SME of the various arrays are programmed to function as anodes and cathodes. The generated electrical pulse wave that passes from the ASIC of the IPI to the associated internal lead wire, ultimately to its associated terminal surface metal electrode. The current then passes a short distance from the stimulations tissue (i.e., trigeminal, or nearby, electrode), whereby it passes back up the lead to its associated proximal metal contact and then back to the IPI to complete the circuit. The generated pulse waves pass through the subcutaneous tissue between two terminal electrodes that stimulates the sensory nerves of the area. When active, the IPI may be programmed to produce continuous series of pulse waves of specified frequency, amplitude, and pulse width. It is this series of pulse waves that effectively stimulates a patient's locally associated nerves that undergoes the therapeutic effect of the implanted unit. The electrical pulse wave then passes from a connected proximal surface metal contact, along the associated internal lead wire, and ultimately to its associated terminal surface metal contact.

It is to be understood that the implementation disclosed herein is not limited to the particular system or processes described which might, of course, vary. It is also to be understood that the terminology used herein is for the purpose of describing particular implementations only, and is not intended to be limiting. As used in this specification, the singular forms "a", "an" and "the" include plural referents unless the context clearly indicates otherwise. In addition, the term "coupling" includes direct and/or indirect coupling of members.

Although the present disclosure has been described in detail, it should be understood that various changes, substitutions and alterations may be made here to without departing from the spirit and scope of the disclosure as defined by the appended claims. Moreover, the scope of the present application is not intended to be limited to the particular embodiments of the process, machine, manufacture, composition of matter, means, methods and steps described in the specification. As one of ordinary skill in the art will readily appreciate from the disclosure, processes, machines, manufacture, compositions of matter, means, methods, or steps, presently existing or later to be developed that perform substantially the same function to achieve substantially the same result as the corresponding embodiment described herein may be utilized according to the present disclosure. Accordingly, the appended claims are intended to include within their scope such processes, machines, manufacture, compositions of matter, means, methods, or steps.

It will be appreciated by those skilled in the art having the benefit of this disclosure that this implantable lead, mounted, neuromodulation system for head pain provides a lead body constructed with implanted leads to cover the frontal, parietal, and occipital regions of the head. It should be understood that the drawings and detailed description herein are to be regarded as illustrative rather than restrictive and examples are not intended to be limiting to the particular forms and examples disclosed. On the contrary, included are any further modifications, changes, rearrangements, substitutions, alternatives, design choices, and embodiments apparent to those of ordinary skill in the art, without departing from the spirit and scope hereof, as defined by the following claims. Thus, it is intended that the following claims be interpreted to encompass all such further modifications, changes, rearrangements, substitutions, alternatives, design choices, and embodiments.

What is claimed is:

1. A head treated neurostimulator, comprising:
 - a main body, the main body comprising:
 - a power source; and
 - a processor, the processor operative to generate a first and second set of stimulating signals for output or associated first set and second set of stimulating outputs;
 - a first wire bundle having a first set and a second set of stimulating conductors, each connected to associated elements of the first set and second set of stimulating outputs, respectively;
 - a first elongated lead body extending from the main body to a distal end, the first elongated lead body configured to contain at least a portion of the first wire bundle, the first elongated lead body being fabricated from a flexible material;
 - a first array of surface electrodes comprising first electrodes spaced apart by a first inter-electrode spacing and disposed along a first portion of the length of the first elongated lead body, the first array of surface electrodes connected to the first set of stimulating conductors;
 - a second array of surface electrodes comprising second electrodes spaced apart by a second inter-electrode spacing disposed along a second portion of the length of the first elongated lead body, the second array of surface electrodes connected to the second set of stimulating conductors, wherein the first portion and second portion are separated by an inter-array interval and wherein the first inter-electrode spacing, the second inter-electrode spacing and the inter-array interval are different distances; and

- a covering over the main body fabricated from the flexible material and merged with the flexible material of the first elongated lead body to form a unitary sealed assembly comprising the main body and the first elongated lead body;
2. The neurostimulator of claim 1, wherein the processor and the power source in the main body are contained in a metal housing;
3. The neurostimulator of claim 1, wherein the processor further includes communication capabilities with a wireless communication link and the main body further includes an antenna associated with the communication link;
4. The neurostimulator of claim 1, wherein the power source comprises a battery;
5. The neurostimulator of claim 1, wherein the processor is operable to generate the first set and second set of stimulating signals with a first and second series of pulse waves of specified frequency, amplitude, and pulse width, respectively;
6. The neurostimulator of claim 1, wherein the first array of surface electrodes includes at least two types of surface electrodes, one for exciting surrounding tissue and the other for completing a circuit back to the processor;
7. The neurostimulator of claim 1, wherein the first electrodes of the first array of surface electrodes are arranged in pairs, each pair having an excitatory electrode and a return or electrode for completing the circuit;
8. The neurostimulator of claim 1, wherein the first array of surface electrodes and the second array of surface electrodes are each configured to independently receive the first set of stimulating signals and the second set of stimulating signals, respectively, from the processor;
9. The neurostimulator of claim 1, wherein the first array of surface electrodes is configured for placement in subcutaneous tissue proximate to a frontal region containing the supraorbital nerve and associated nerves in proximity there to and the second array of surface electrodes is configured for placement in subcutaneous tissue proximate to a parietal region containing the auricular-occipital nerve, as well as adjacent occipital nerves;
10. The neurostimulator of claim 1, and further comprising a second elongated lead body that extends from the main body to a second elongated lead body distal end, the second elongated lead body comprising a third set of stimulating conductors, each stimulating conductor connected to associated elements of a third set of stimulating outputs associated with a third set of stimulating signals. From the processor, the second elongated lead body fabricated from the flexible material and merged with the flexible material covering the main body and the first elongated lead body; and the second elongated lead body further comprising a third plurality of surface electrodes disposed along the length thereof and connected to the third set of stimulating conductors;
11. The neurostimulator of claim 1, wherein the flexible material is fabricated from a medical grade plastic;
12. A unitary implantable neurostimulator, comprising:
 - an enclosure having a first enclosed portion and a second enclosed portion, the first enclosed portion and the second enclosed portion comprising a common unitary enclosure, the enclosure unitary interior comprising:
 - a power source;
 - a processor operative to generate a first stimulation signal and a second stimulation signal, wherein the first and second stimulation signals are different signals and a plurality of outputs comprising a first output for the first stimulation signal and a second output for the second stimulation signal; and

15

a first stimulation lead having one end integrated with the auxiliary interface, the first stimulation lead having a longitudinal shape and at least one terminus end, the first stimulation lead comprising:

a first plurality of stimulation conductors disposed along the length of the first stimulation lead, each having first ends and second ends, wherein a first end of a first one of the first plurality of stimulation conductors is interfaced with the first output end a first end of a second one of the first plurality of stimulation conductive wires is interfaced with the second output;

a first plurality of surface electrodes spaced a first inter-electrode distance apart and disposed along the length of a first portion of the first stimulation lead wherein one of the first plurality of surface electrodes is connected to a second end of the first one of the first plurality of stimulation conductors; and

a second plurality of surface electrodes spaced a second inter-electrode distance apart and disposed along the length of a second portion of the first stimulation lead, wherein the second portion and the first portion of the first stimulation lead are separated by a defined inter-array interval, wherein the first inter-electrode distance, the second inter-electrode distance and the inter-array interval are different distances, and wherein one of the second plurality of surface electrodes is connected to a second end of the second one of the first plurality of stimulation conductors.

13. The neurostimulator of claim 12, wherein the enclosure is shaped to facilitate internal implantation posterior and cephalad to the plane of the ear.

14. The neurostimulator of claim 13, wherein the first stimulation lead is dimensioned to facilitate subdermal implantation in a particular site so that the first stimulation lead is configured to extend from the ear canal substantially across the patient's parietal bone to extend the occipital and access a portion of the patient's frontal bone.

15. The neurostimulator of claim 14, wherein the first plurality of surface electrodes are configured to be positioned and dispersed over a frontal region proximate to the patient's frontal bone so that they are associated with the supraorbital nerve bundle and associated nerves in proximity thereto.

16. The neurostimulator of claim 14, wherein the second plurality of surface electrodes are configured to be positioned and dispersed over a parietal region proximate to the patient's parietal bone and the major associated nerves, including the auriculo-temporal nerve, as well as adjacent cutaneous nerves.

17. The neurostimulator of claim 12, wherein the enclosure is flexible.

18. The neurostimulator of claim 12, further comprising: the processor operable to generate a third stimulation signal different from the first and second stimulation signals;

the plurality of outputs comprising a third output for the third stimulation signal;

a second stimulation lead having one end of the second stimulation lead integrated with the auxiliary interface; the second stimulation lead having a longitudinal shape and at least one terminus end, the second stimulation lead comprising:

a second plurality of stimulation conductors each having first ends and second ends, wherein a first end of a first one of the second plurality of stimulation conductors is interfaced with the third output of the plurality of outputs providing the third stimulation signal;

16

a third plurality of surface electrodes disposed along a first portion of the second stimulation lead wherein one of the third plurality of surface electrodes is connected to a second end of the first one of the second plurality of stimulation conductors.

19. The neurostimulator of claim 18, wherein the surface electrodes are arranged in at least one first grouping of surface electrodes arranged to be dispersed over and proximate to the patient's frontal bone such that the first grouping of surface electrodes are associated with the patient's supraorbital nerve bundle and associated nerves in proximity thereto;

wherein the second portion has a second grouping of surface electrodes disposed thereon which are arranged to be positioned and dispersed over and proximate to the patient's parietal bone and the major associated nerves, including the auriculo-temporal nerve, as well as adjacent cutaneous nerves; and

wherein the second portion has a third grouping of surface electrodes disposed thereon which are arranged to be positioned and dispersed over and proximate to the patient's occipital bone and the associated nerves, including at least one of the greater occipital nerve, the lesser occipital nerve and third occipital nerve.

20. A neurostimulator device comprising:

a main body, the main body comprising:

a power source; and

a processor connected to the power source, the processor configured to generate a first set of stimulating signals and a second set of stimulating signals for output on an associated first set and second set of stimulating outputs.

a first wire bundle having a first set of conductors connected to the first set of stimulating outputs and a second set of conductors connected to the second set of stimulating outputs;

a first elongated lead body extending from the main body to a distal end, the first elongated lead body configured to contain at least a first portion of the first wire bundle, the first elongated lead body being fabricated from flexible material;

a first array of surface electrodes having a first inter-electrode spacing and disposed along a first portion of the length of the first elongated lead body, the first array of surface electrodes being connected to the first set of conductors;

a second array of surface electrodes having a second inter-electrode spacing different from the first inter-electrode spacing and disposed along a second portion of the length of the first elongated lead body, the second array of surface electrodes being connected to the second set of conductors, the first portion and the second portion of the length of the first elongated lead body being separated by an inter-array interval different from both the first and second inter-electrode spacings; and

the neurostimulator device being configured for surgical implantation only in subcutaneous tissue of a human's head.

21. The neurostimulator device of claim 20, wherein the processor is further configured to generate a third set of stimulating signals for output on a third set of stimulating outputs, wherein the first wire bundle further comprises a third set of conductors connected to the third set of stimulating outputs, the neurostimulator device further comprising:

a second elongated lead body extending from the main body to a second elongated lead body distal end, the second elongated lead body configured to contain at least a

second portion of the first wire bundle, the second elongated lead body being fabricated from flexible material; and

- c. third array of surface electrodes having a fixed inter-electrode spacing and disposed along a portion of the length of the second elongated lead body, the third array of surface electrodes being connected to the third set of conductors.

21. The neurostimulator device of claim 20, wherein the first portion of the length of the first elongated lead body is configured to be cranially positioned over a auricular nerve region and the second portion of the length of the first elongated lead body is configured to be cranially positioned over a supraorbital nerve region of a human cranium when the neurostimulator device is surgically implanted, only in subcutaneous tissue of the human cranium.

23. The neurostimulator device of claim 21, wherein the first portion of the length of the first elongated lead body is configured to be cranially positioned over a parietal region proximate the auriculo-temporal nerve, the second portion of the length of the first elongated lead body is configured to be cranially positioned over a frontal region proximate the supraorbital nerve, and the portion of the length of the second elongated lead body is configured to be cranially positioned over an occipital region proximate the occipital nerve when the neurostimulator device is surgically implanted, only in subcutaneous tissue of the cranium.

* * * * *